

BASIC-LINE

Cable carriers with fixed chain widths

UNIFLEX Advanced 1555

Design	Page
1555.020	2
1555.030	3
1555.040	4
Anschlussstücke 1555	5

Design 1555.020
With fixed brackets.

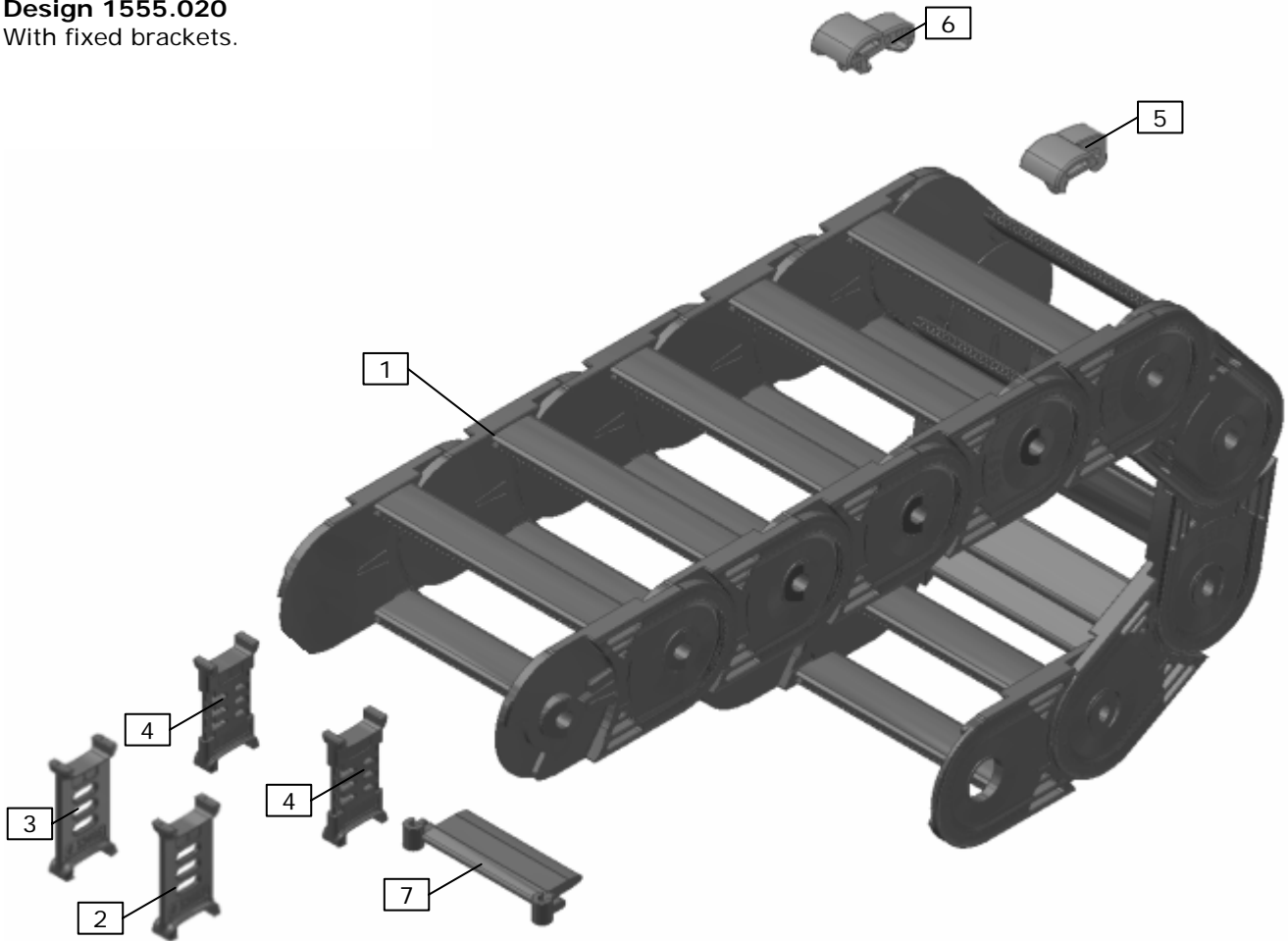

Item	Description	Bi 50	Bi 75	Bi 100	Bi 125	Bi 150
1 ¹	1555.020 KR 63	53500	53507	53514	53521	53528
	1555.020 KR 80	53501	53508	53515	53522	53529
	1555.020 KR 100	53502	53509	53516	53523	53530
	1555.020 KR 125	53503	53510	53517	53524	53531
	1555.020 KR 160	53504	53511	53518	53525	53532
	1555.020 KR 200	53505	53512	53519	53526	53533
	1555.020 KR 230	53506	53513	53520	53527	53534

Item	Description / Remarks	Material No.
2	Divider 1555 Standard / $S_T=2.5\text{mm}$	53667
3	Divider 1555 fixed / grid 2.5mm, $S_T=2.5\text{mm}$	53666
4	Divider 1555 TS3, $S_T=5\text{mm}$	53665
5	Outside damper 1555 right	53682
6	Outside damper 1555 left	53683

Item	Plastic height separation - for height separation with divider item 5 ²								
7	Width	15	20	25	30	35	40	45	55
	Material No.	52570	52571	52572	52573	52574	52575	52576	52577
	Width	65	75	-	-	-	-	-	-
Material No.	52578	52579	-	-	-	-	-	-	

¹ Material number for 1 piece cable carrier, 18 chain links=1000mm

² chamber width=width-5mm, thickness=2.4mm

Design 1555.030

Outside: Hinged, openable and detachable brackets

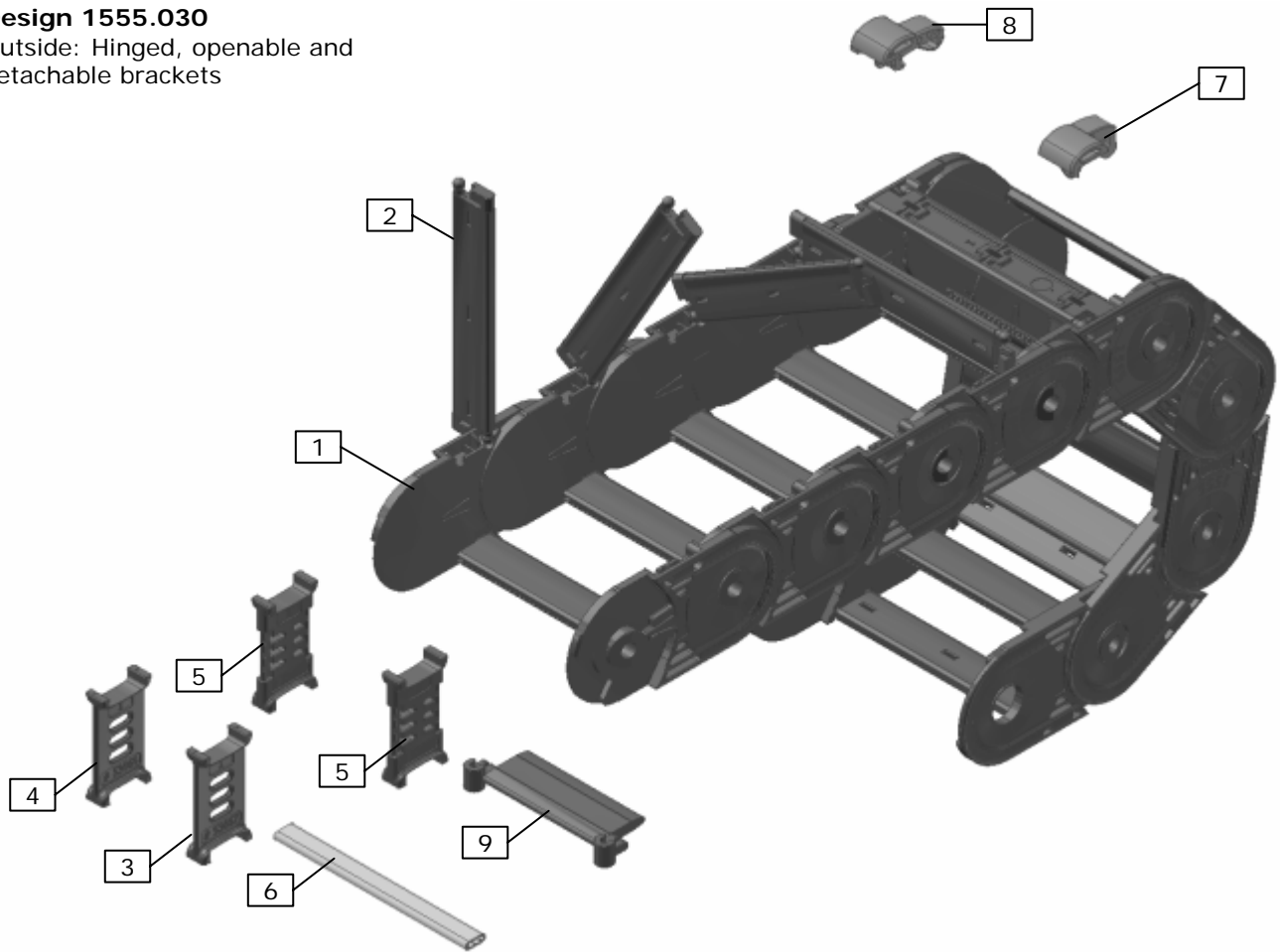

Item	Description	Bi 50	Bi 75	Bi 100	Bi 125	Bi 150
1 ³	1555.030 KR 63	53549	53556	53563	53570	53577
	1555.030 KR 80	53550	53557	53564	53571	53578
	1555.030 KR 100	53551	53558	53565	53572	53579
	1555.030 KR 125	53552	53559	53566	53573	53580
	1555.030 KR 160	53553	53560	53567	53574	53581
	1555.030 KR 200	53554	53561	53568	53575	53582
	1555.030 KR 230	53555	53562	53569	53576	53583
2	Bracket 1555	53647	53648	53649	53650	53651

Item	Description / Remarks	Material No.
3	Divider1555 not fixed, $S_T=2.5\text{mm}$	53667
4	Divider 1555 fixed / grid 2.5mm, $S_T=2.5\text{mm}$	53666
5	Divider 1555 TS3, $S_T=5\text{mm}$	53665
6	Al-hollow profile 11x4, for continuous height separation TS1, $L=Bi-1\text{mm}$	5803
7	Outside damper 1555 right	53682
8	Outside damper 1555 left	53683

Item	Plastic height separation - for height separation with divider item 5 ⁴								
9	Width	15	20	25	30	35	40	45	55
	Material No.	52570	52571	52572	52573	52574	52575	52576	52577
	Width	65	75	-	-	-	-	-	-
	Material No.	52578	52579	-	-	-	-	-	-

³ Material number for 1 piece cable carrier with brackets assembled, 18 chain links=1000mm

⁴ chamber width=width-5mm, thickness=2.4mm

Design 1555.040

Inside: Hinged, openable and detachable brackets.

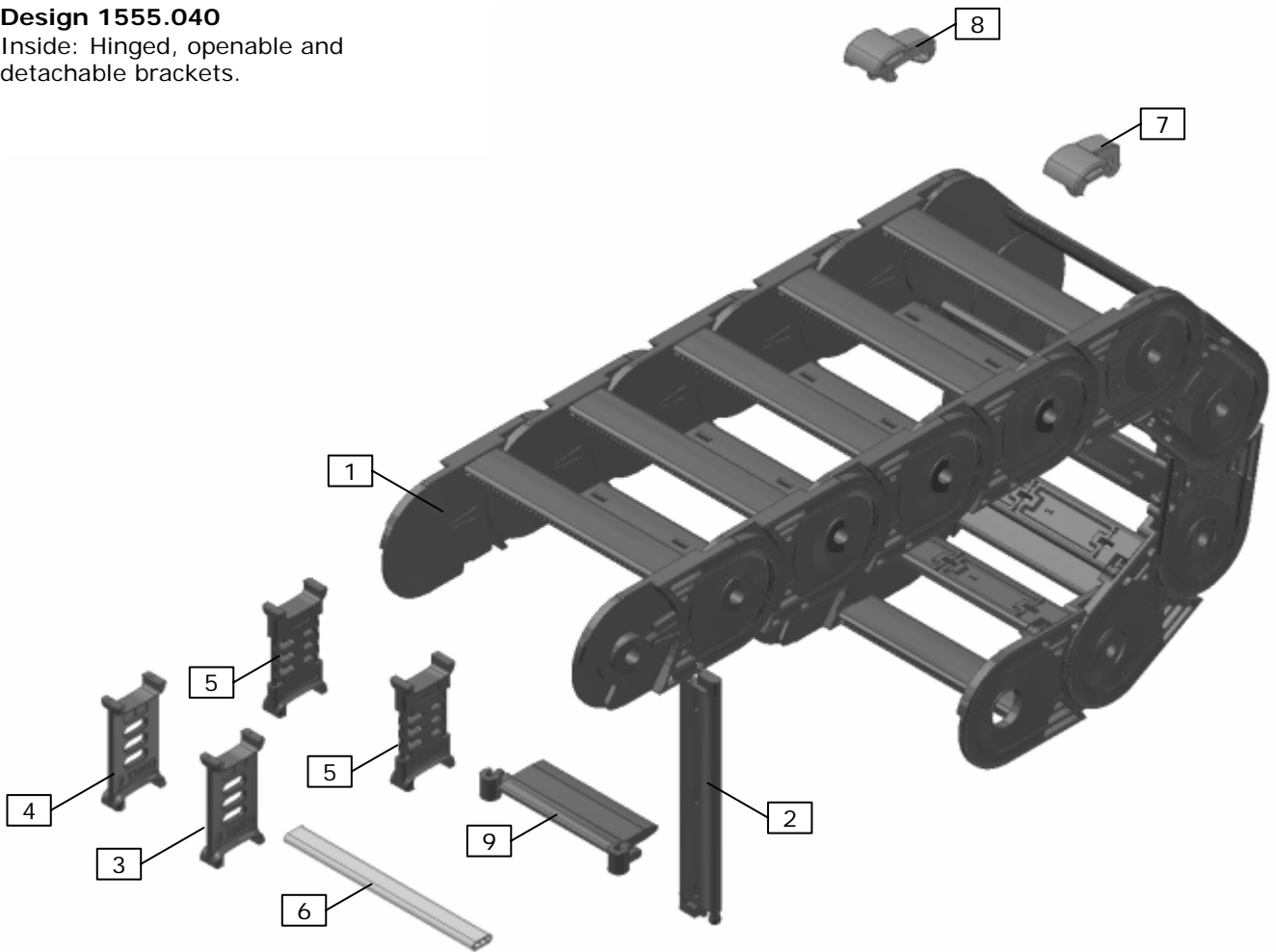

Item	Description	Bi 50	Bi 75	Bi 100	Bi 125	Bi 150
1 ⁵	1555.040 KR 63	53598	53605	53612	53619	53626
	1555.040 KR 80	53599	53606	53613	53620	53627
	1555.040 KR 100	53600	53607	53614	53621	53628
	1555.040 KR 125	53601	53608	53615	53622	53629
	1555.040 KR 160	53602	53609	53616	53623	53630
	1555.040 KR 200	53603	53610	53617	53624	53631
	1555.040 KR 230	53604	53611	53618	53625	53632
2	Bracket 1555	53647	53648	53649	53650	53651

Item	Description / Remarks	Material No.
3	Divider 1555 not fixed, $S_T=2.5\text{mm}$	53667
4	Divider 1555 fixed / grid 2.5mm, $S_T=2.5\text{mm}$	53666
5	Divider 1555 TS3, $S_T=5\text{mm}$	53665
6	Al-hollow profile 11x4, for continuous height separation TS1, $L=Bi-1\text{mm}$	5803
7	Outside damper 1555 right	53682
8	Outside damper 1555 left	53683

Item	Plastic horizontal divider for height separation with divider item 5 ⁶								
9	Width	15	20	25	30	35	40	45	55
	Material No.	52570	52571	52572	52573	52574	52575	52576	52577
	Width	65	75	-	-	-	-	-	-
	Material No.	52578	52579	-	-	-	-	-	-

⁵ Material number for 1 piece cable carrier with brackets assembled, 18 chain links=1000mm

⁶ chamber width=width-5mm, thickness=2.4mm

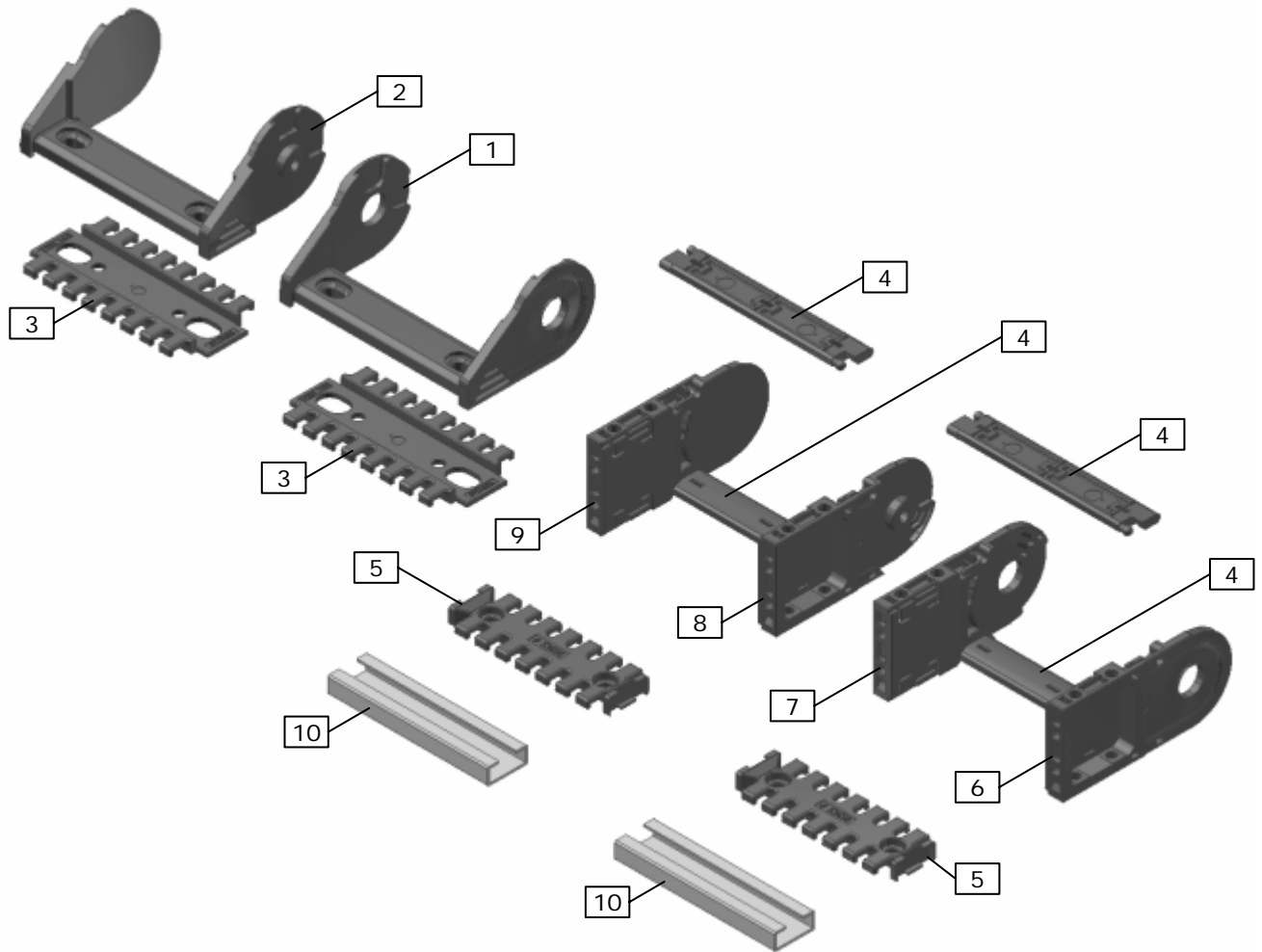

Item	Description / Remarks	Bi 50	Bi 75	Bi 100	Bi 125	Bi 150
1	Connecting piece 1555 Driver / Plastic	53669	53671	53673	53675	53677
2	Connecting piece 1555 Fixed point / Plastic	53668	53670	53672	53674	53676
3	Strain relief / Plastic	53684	53685	53686	53687	53688
4	Bracket 1555 / Plastic	53647	53648	53649	53650	53651
5	Strain relief 1555 UMB / for item 6-9, Plastic	53654	53655	53656	53657	53658

Item	Description / Remarks	Material No.
6	Universal end connector 1555 Driver right side / Plastic	53661
7	Universal end connector 1555 Driver left side / Plastic	53662
8	Universal end connector 1555 Fixed point right side / Plastic	53663
9	Universal end connector 1555 Fixed point left side / Plastic	53664
10	Strain relief 25x10 / L=Bi-1mm, Steel	3931