

KABELSCHLEPP GmbH
Daimlerstraße 2
D-57482 Wenden-Gerlingen
Fon: +49 2762 4003-0
Fax: +49 2762 4003-220
E-mail: info@kabelschlepp.de
kabelschlepp.de

TUBE-SERIES

Covered Cable carriers with fixed chain widths

CoverTrax Type CT 1555

Type	Page
CT 1555.080	2
Connectors CT 1555.....	3

CT 1555.080

Outside: Hinged, openable (on the right/left) and detachable cover

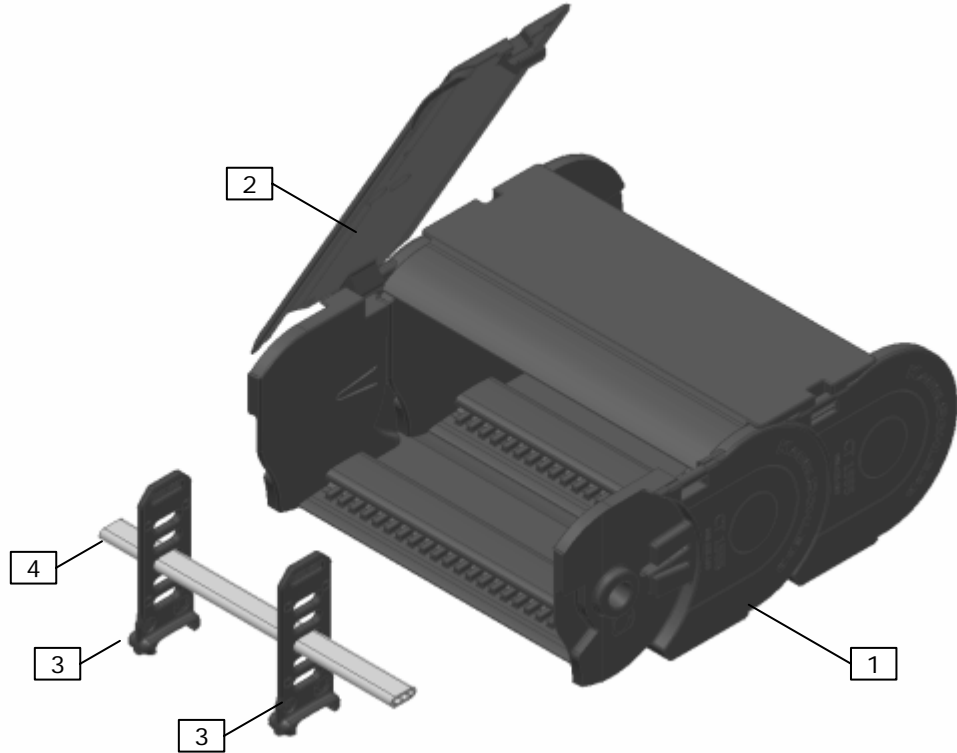

Item	Description	KR 100	KR 125	KR 150	KR 175	KR 200	KR 225	KR 250	KR 300
1 ¹	CT 1555.080.050	55430*	55431*	55432*	55433*	55434*	55435*	55436*	55437*
	CT 1555.080.075	55438*	55439*	55440*	55441*	55442*	55443*	55444*	55445*
	CT 1555.080.100	55446*	55447*	55448*	55449*	55450*	55451*	55452*	55453*
	CT 1555.080.115	55454*	55455*	55456*	55457*	55458*	55459*	55460*	55461*
	CT 1555.080.125	55462	55463*	55464*	55465*	55466*	55467*	55468*	55469*
	CT 1555.080.150	55470*	55471*	55472*	55473*	55474*	55475*	55476*	55477*
	CT 1555.080.175	55478*	55479*	55480	55481*	55482*	55483*	55484*	55485*
	CT 1555.080.200	55486*	55487*	55488*	55489*	55490*	55491*	55492*	55493*
	CT 1555.080.225	53722*	53723*	53724*	53725*	53726*	53727*	53728*	53729*
CT 1555.080.250	53730*	53731*	53732*	53733*	53734*	53735*	53736*	53737*	

Item	Material no.	B _i 50	B _i 75	B _i 100	B _i 115	B _i 125	B _i 150	B _i 175	B _i 200
2 ²	Cover, outside	53712*	53713*	53714*	53715*	53716	53717*	53718	53719*
		B_i 225	B_i 250	–	–	–	–	–	–
2 ²	Cover, outside	53720*	53721*	–	–	–	–	–	–

Item	Description / Remarks	Material No.
3	Divider CT 1555.080 Standard, for TS0 und TS1, S _T =3mm ³	53700
4	Al-Hollow profile 11x4, for continuous height separation TS1, L=B _i -1mm	5803

¹ Material number for 1 piece cable carries with covers mounted, 18 links=1000mm

² Material number for single part

³ Depending on the mounting direction movable or fixed at grid 5mm

* on request

Connectors CT 1555

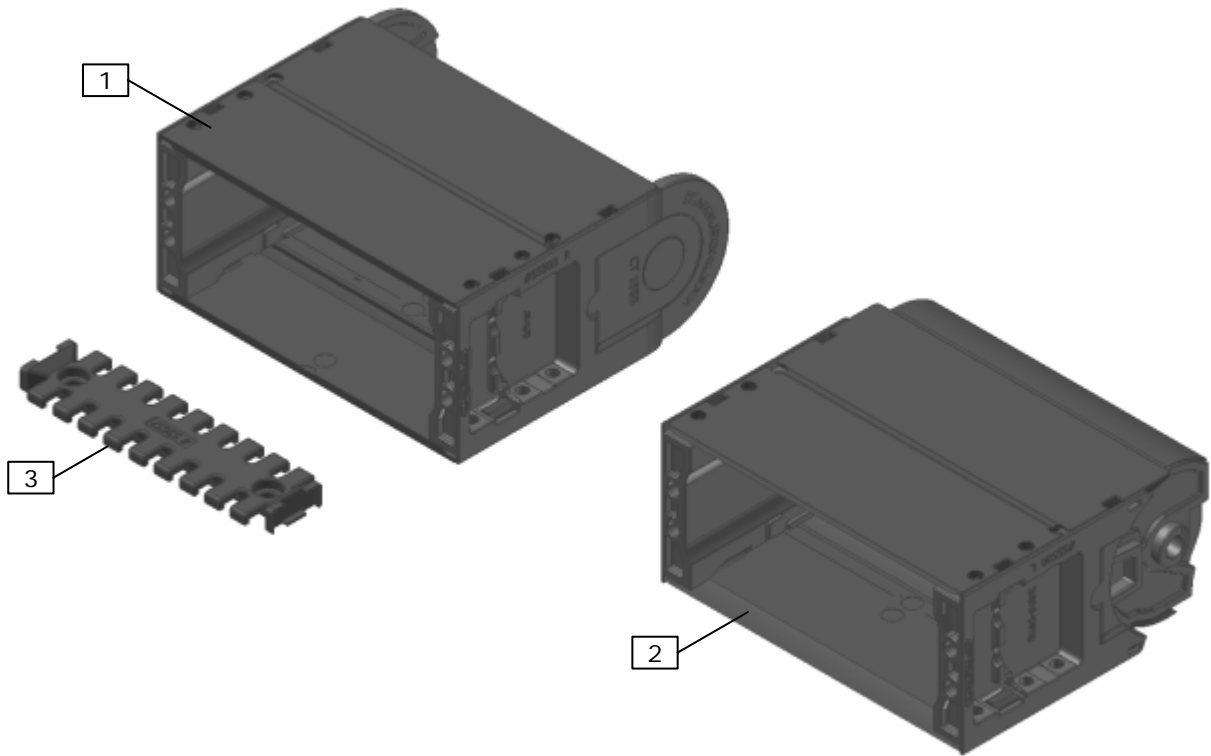

Item	Material No.	B _i 50	B _i 75	B _i 100	B _i 115	B _i 125
1	UMB CT 1555 Driver ¹	53476*	53474*	53472*	53470*	53468
2	UMB CT 1555 Fixed Point	53475*	53473*	53471*	53469*	53467
3	Strain relief UMB, Plastic	53654	53655	53656	–	53657
		B_i 150	B_i 175	B_i 200	B_i 225	B_i 250
1	UMB CT 1555 Driver ¹	53466*	53464	53462*	53460*	53458*
2	UMB CT 1555 Fixed Point	53465*	53463	53461*	53459*	53457*
3	Strain relief UMB, Plastic	53658	53659	–	–	–

Item	Description / Remarks	Material No.
No pic.	Strain relief 25x10 / L=B _i -1mm, Steel	3931

¹ Mat. No. for assembly preassembled, without strain relief
 * on request

IDEAS AROUND THE MACHINE

CABLE CARRIER SYSTEMS

Cable carriers made of steel and plastic
QUANTUM cable and hose carrier system
PROTUM cable and hose carrier system
PROFILE cable and hose carrier system
ROBOTRAX cable and hose carrier system

LIFE-LINE Safety Cables

Continuous bending hi-flex cables for cable carrier
TOTALTRAX complete turn-key carrier systems
Pre-assembled cables

KABELSCHLEPP GmbH

Daimlerstraße 2
D-57482 Wenden-Gerlingen
Fon: +49 2762 4003-0
Fax: +49 2762 4003-220
E-mail: info@kabelschlepp.de
kabelschlepp.de

GUIDEWAY PROTECTION SYSTEMS

Telescopic covers
Link apron covers
Way wipes
Conical spring covers
Bellows
Protective devices

CONVEYOR SYSTEMS

Hinged belt conveyors
Scraper conveyors
Belt conveyors

KABELSCHLEPP worldwide

For contacts, addresses and
much more, visit our web side at
kabelschlepp.de